

# KNOCK-OUT BRACKET - 1 SECTION

64 EACH      32 EACH      16 EACH      8 EACH      4 EACH      2 EACH      1 EACH

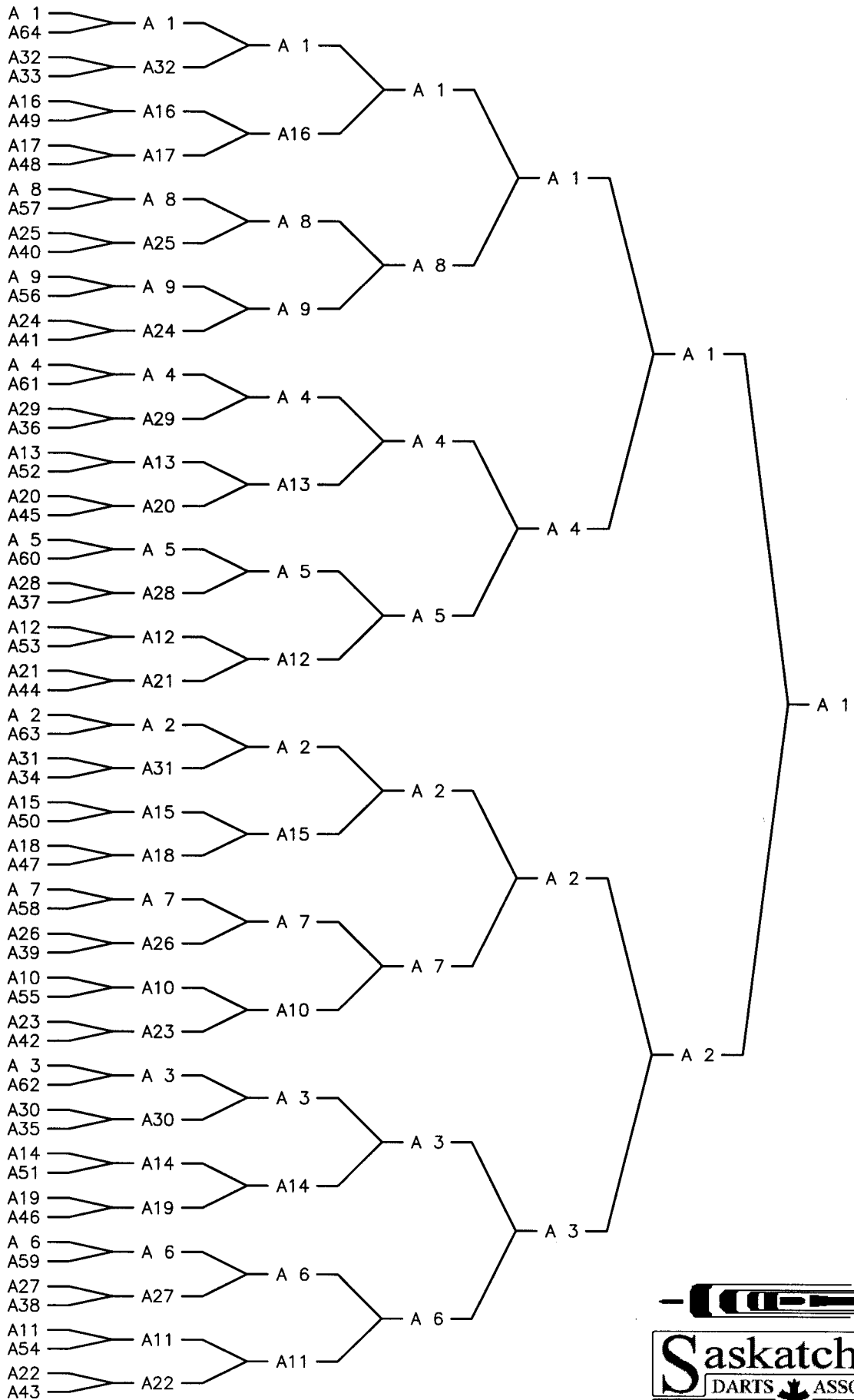

# KNOCK-OUT BRACKET - 2 SECTIONS

32 EACH      16 EACH      8 EACH      4 EACH      2 EACH      1 EACH

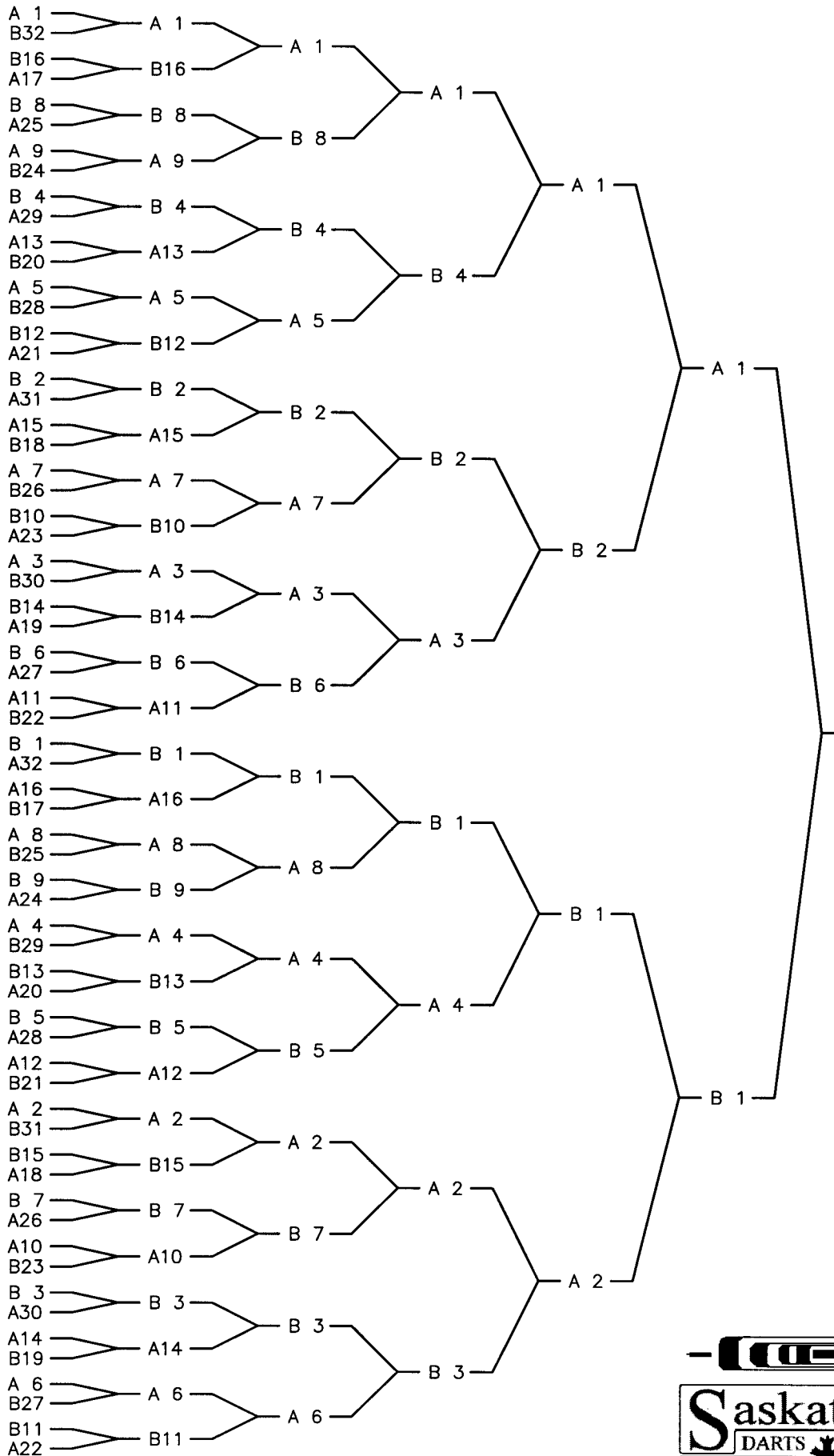

# KNOCK-OUT BRACKET - 4 SECTIONS

16 EACH      8 EACH      4 EACH      2 EACH      1 EACH

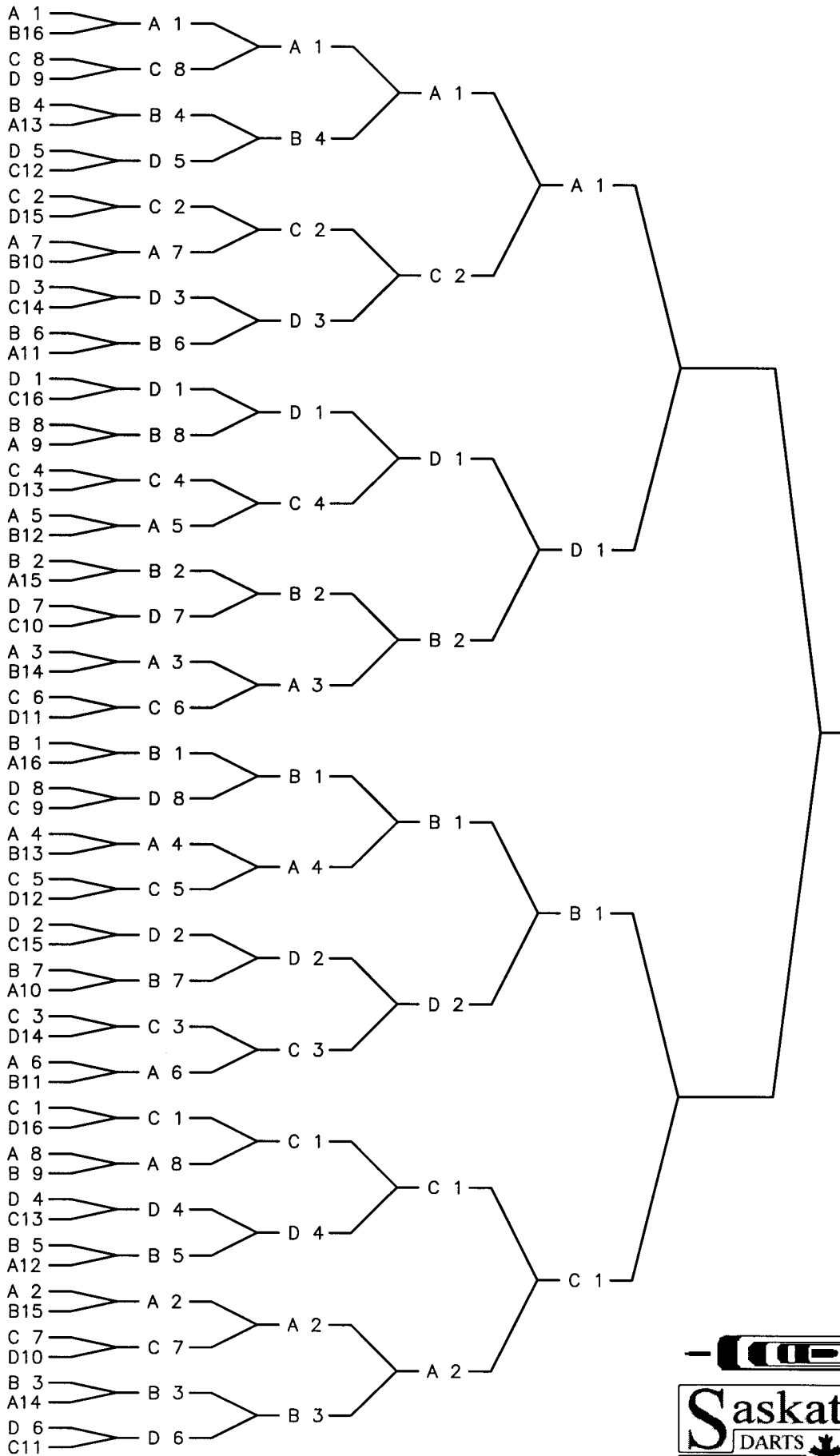

# KNOCK-OUT BRACKET - 8 SECTIONS

8 EACH      4 EACH      2 EACH      1 EACH

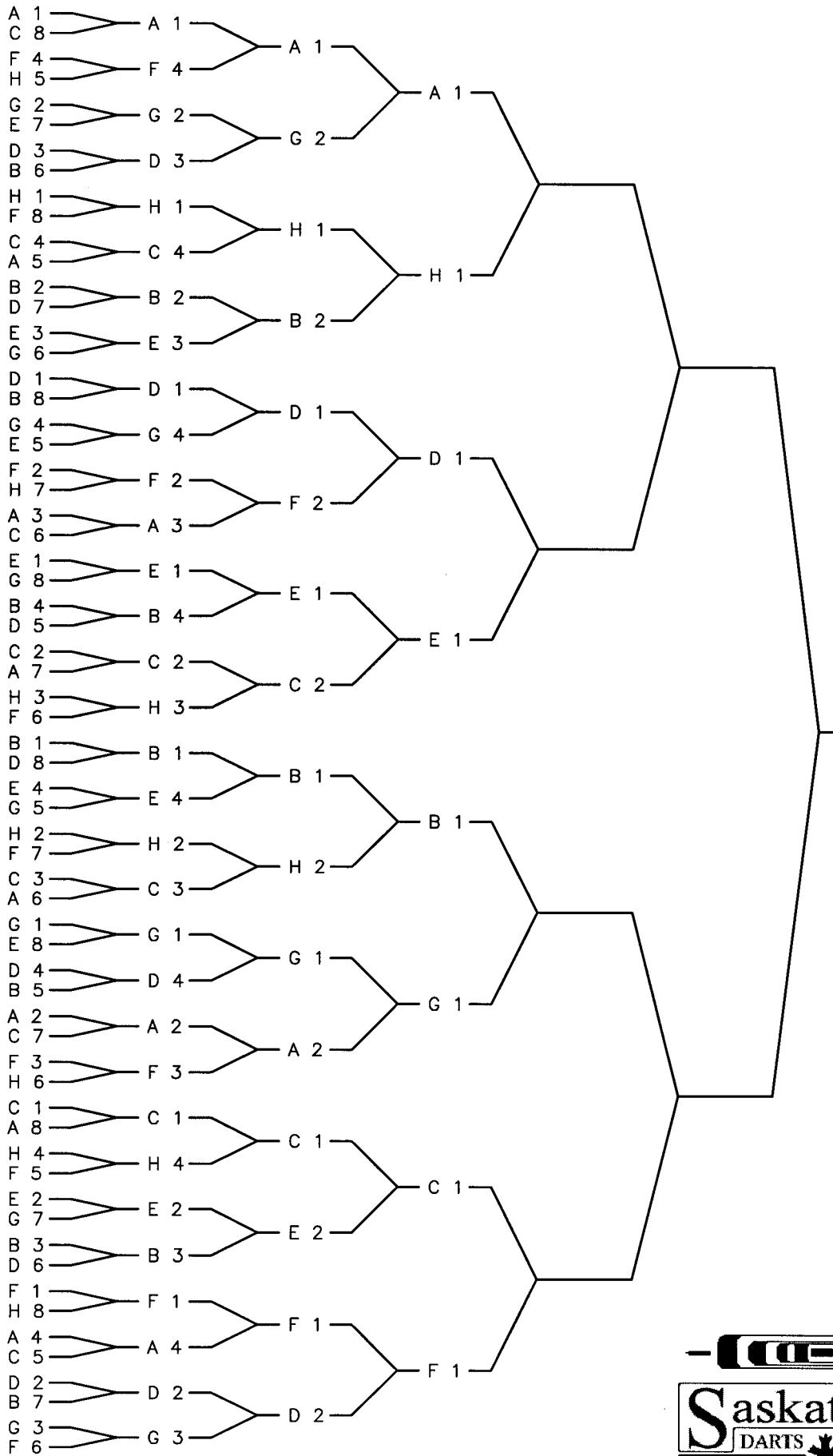

# KNOCK-OUT BRACKET - 16 SECTIONS

4 EACH      2 EACH      1 EACH

